



 **AUTOFRIC**

**Specialists in dewatering  
and bulk transportation**

# COMPLETE SOLUTIONS FOR DEWATERING AND MATERIAL HANDLING



With many years of experience in screw and spiral production, Autofric develops products for highly efficient dewatering of sludge and residues from, e.g., wastewater treatment plants and industrial processes.

## THREE STABLE LEGS

Autofric's business rests on three solid pillars. Unique expertise in screw production, machine design, and application areas enables us to develop products tailored to our customers' requirements.

## BASED ON OUR CUSTOMERS' NEEDS

A collaboration with Autofric often starts in the dialog with you as a customer. We listen carefully and capture the wishes regarding functionality, sustainability, and economy.

We are happy to join in the initial conceptual and design phase.

## HIGHLY EFFICIENT DEWATERING OF SLUDGE AND RESIDUES

A growing range of dewatering products is being developed and produced with a strong focus on sustainability and the environment. The basis is a series of screw presses for highly efficient dewatering of sewage sludge or industrial residues.

## WE WORK FOR SUSTAINABLE SOLUTIONS

Respect for the environment is a fundamental objective in most of our solutions. Sustainability is thus a guiding principle in development, production and in our choice of materials.

## Our product areas

Autofric is a leading manufacturer in material handling, offering a wide range of innovative solutions for efficient and sustainable production. We combine high quality products with industry expertise and focus on five main product areas.

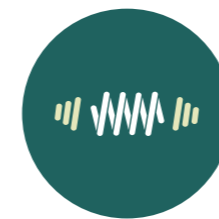

### SCREW PRESSES

Screw presses for dewatering sludge from municipal wastewater treatment plants and industrial processes. Screw presses are offered in different sizes and capacities.

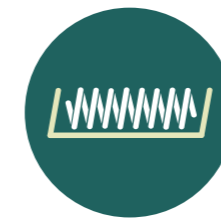

### SCREW CONVEYORS

Robust, energy-efficient, and customized screw conveyors effectively move materials such as chips, sludge, pulp, sand, and ash both horizontally and vertically.

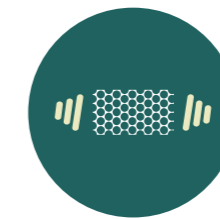

### SLUDGE CLEANERS

Sludge cleaners reduce blockages, downtime, and maintenance costs, ensuring efficient, reliable operation in both municipal facilities and across a variety of industrial environments.

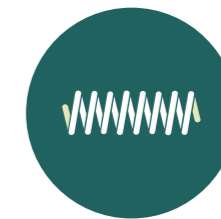

### TRANSPORT SCREWS

Customer-unique transport screws with high wear resistance in a variety of dimensions and materials. Offered both for new projects and as spare parts.

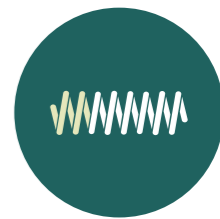

### SCREW SEGMENTS

Screw segments offer diverse options for material, dimensions and finished design of the screw. Segments enhance flexibility by enabling unique cuts with different properties.

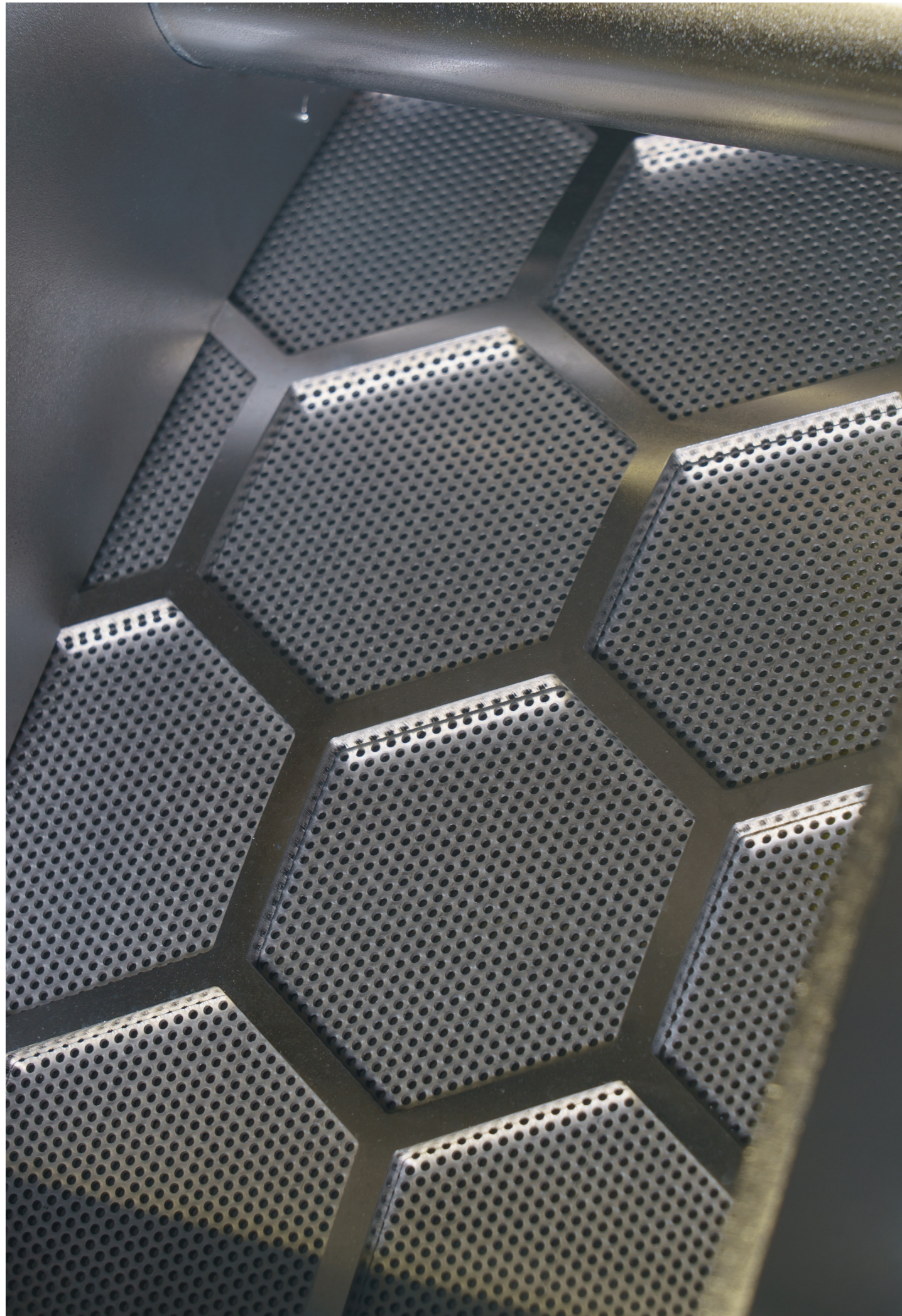

# SCREW PRESSES

Autofric offers a range of high-quality screw presses for efficient dewatering of sewage sludge or industrial residues. By employing advanced technologies and innovative design features, Autofric's screw presses are able to achieve remarkable levels of dewatering efficiency, extracting maximum moisture from the input materials with minimal energy consumption.



### WASTEWATER TREATMENT

In water and wastewater treatment, there is a great need to separate, transport, and dewater particles and sludge. Several of Autofric's products have been developed to streamline and minimize the costs of these processes.



### INDUSTRIAL PROCESSES

The industry's need for dewatering is increasing both in in-house processes and in the handling of residual products. Autofric's screw presses are well-received on the market, making a decisive contribution to cost-effective material handling.



### FOOD PREPERATION

In the food industry, Autofric's screw presses are excellent dewatering options in both food preparation and waste management. The applications are countless and include, e.g., dewatering of seaweed and in the preparation of onions before roasting.



Autofric has developed a comprehensive line of state-of-the-art screw presses, engineered to deliver unparalleled efficiency in the dewatering process while minimizing environmental impact.

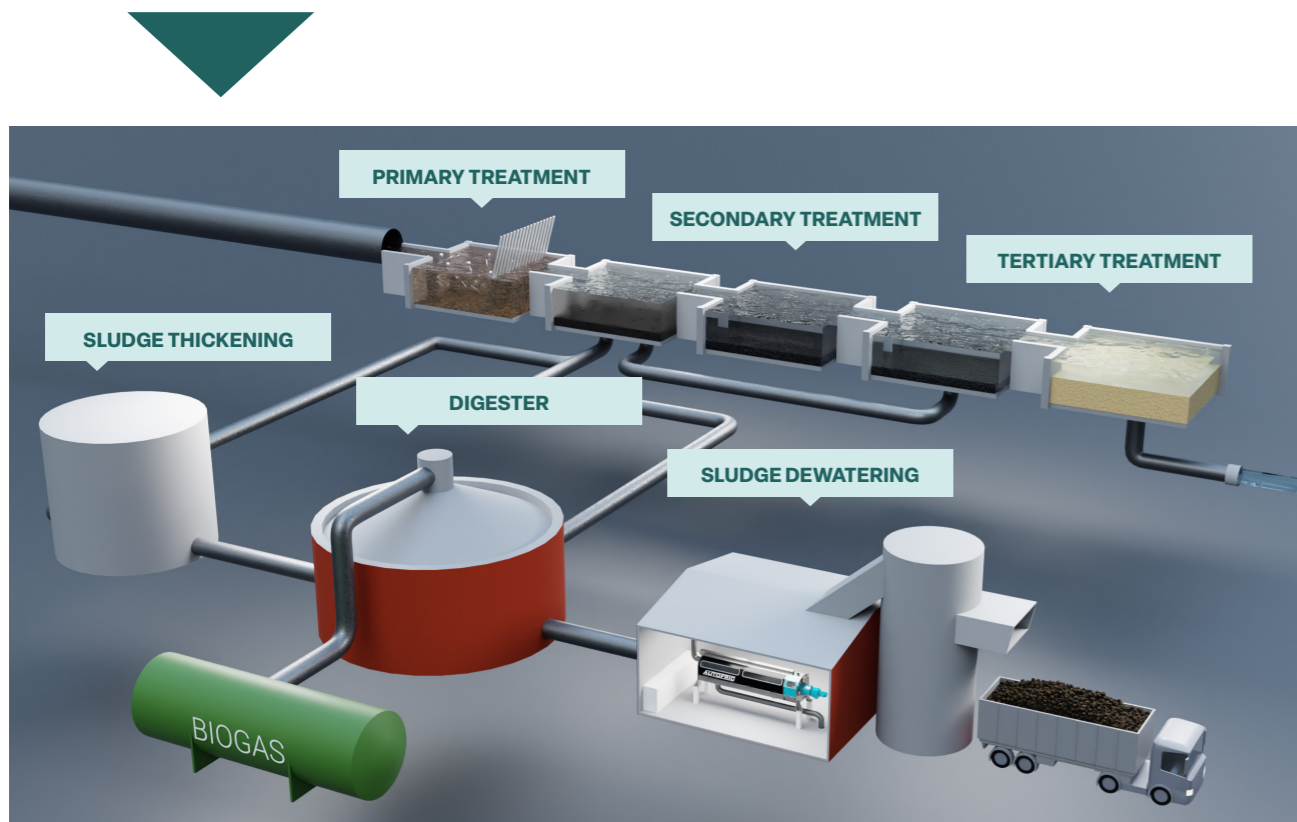

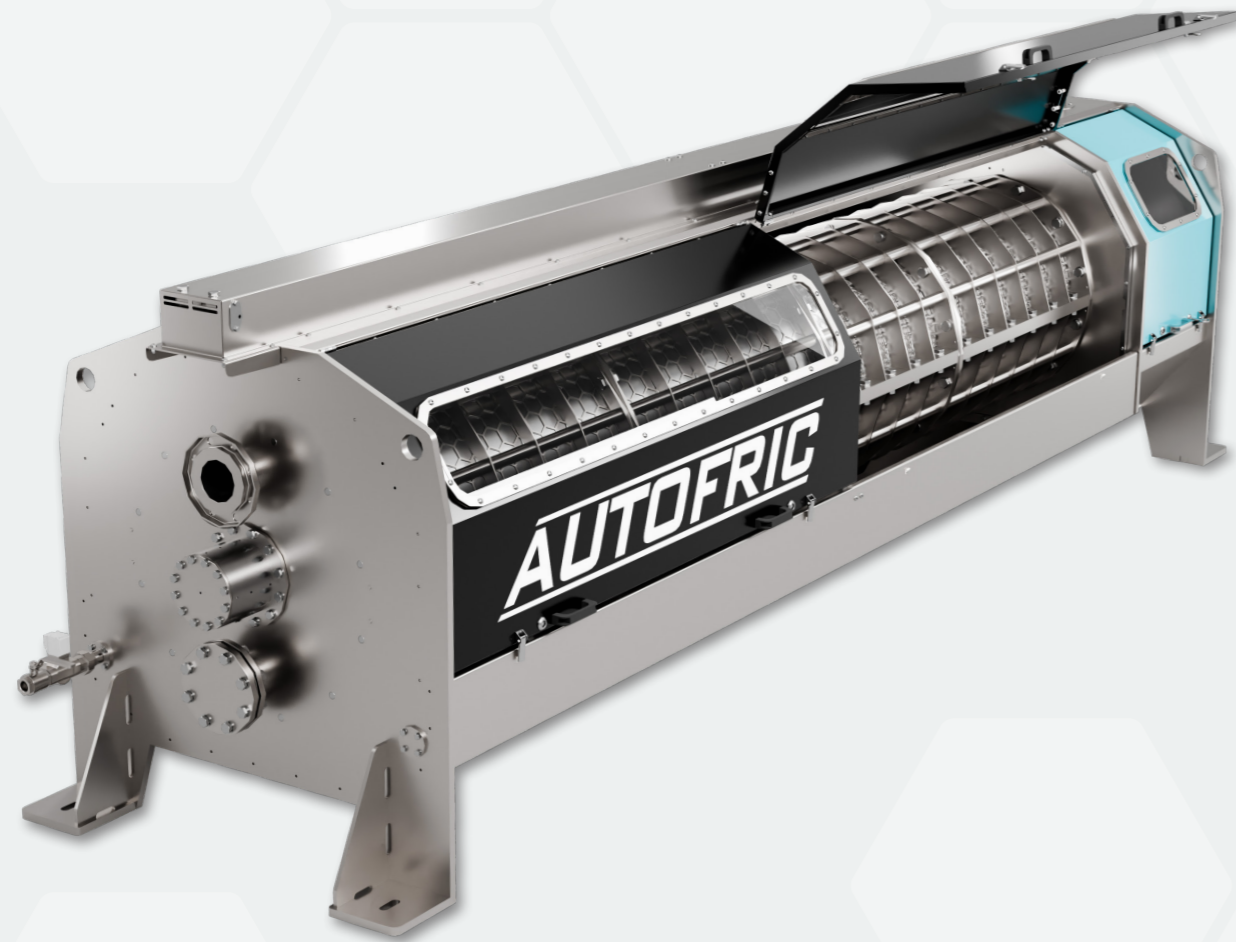

## Autofric ASP



Autofric ASP is a high-performance, energy-efficient screw press for dewatering of sludge from, for example, municipal treatment plants. The press is built around a precision-manufactured stainless steel conical screw that rotates through multiple dewatering zones inside a dividable screen basket. The large dewatering area allows for thickening and dewatering in the same machine.

The machine's design, with a stable, fully enclosed chassis and few moving parts, makes it easy to handle. The press works quietly, vibration-free, and energy-efficiently with low wear and minimal maintenance needs, which contributes to a safe and hygienic working environment and a low operating budget.

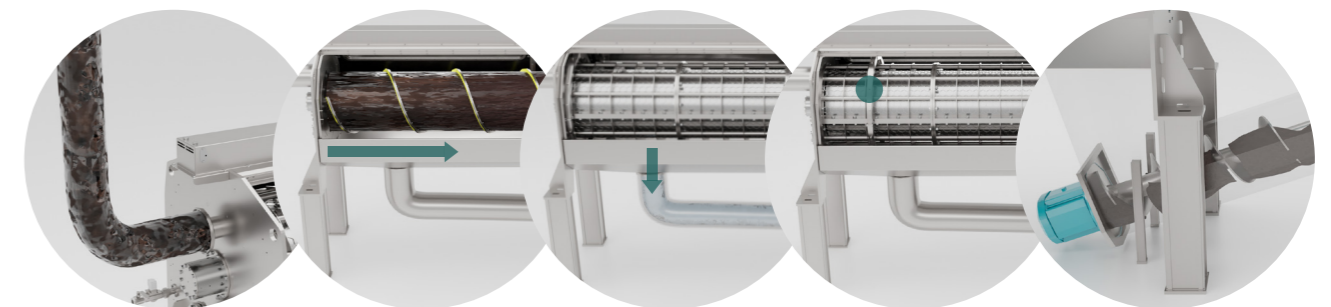
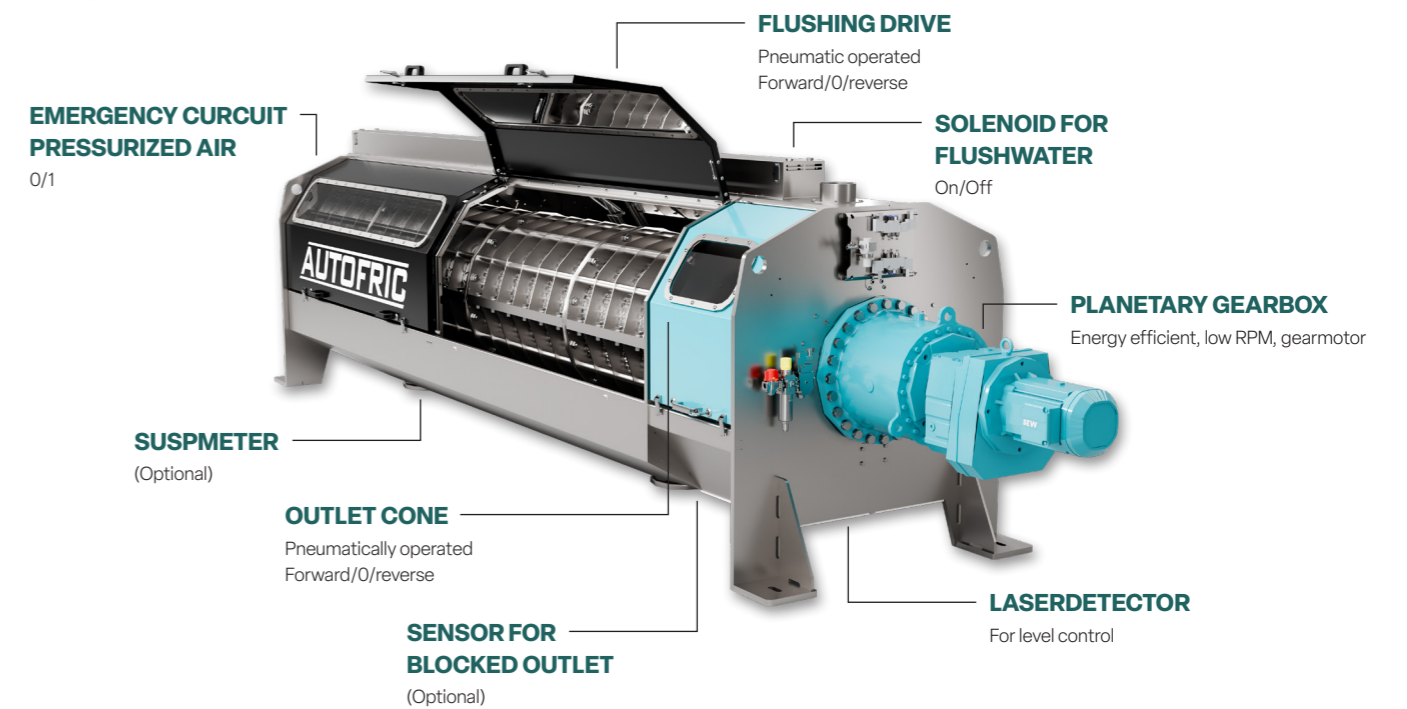

- 1** Flocculated sludge with a high water content enters the machine.
- 2** The spiral presses the sludge forward.
- 3** The water is separated from the sludge through the sieve.
- 4** The spraybar cleans the sieve intermittently when needed.
- 5** The dewatered sludge exits the press and is conveyed to temporary storage.

Model	Length (mm)	Width (mm)	Height (mm)	Weight (kg)	Motor (kW)	Kg DS (kg/h)
ASP73	2650	760	1050	750	0,55	63*
ASP154	3900	900	1100	1400	0,75	152*
ASP205	5100	1050	1050	2800	2,20	211*
ASP406	5560	1150	1150	3500	3,00	392*
ASP507	6180	1250	1250	4500	3,00	500*
ASP658	6900	1450	1850	6800	4,00	653*
ASP859	7900	1700	2000	7500	5,50	852*
ASP1010	8350	1750	2150	8800	5,50	1005*

DS 17-38%. Capacity 5-1005 kg DS/h.

\*Capacity digested sludge 2,5% DS.

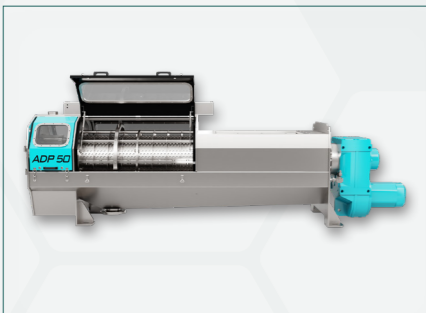
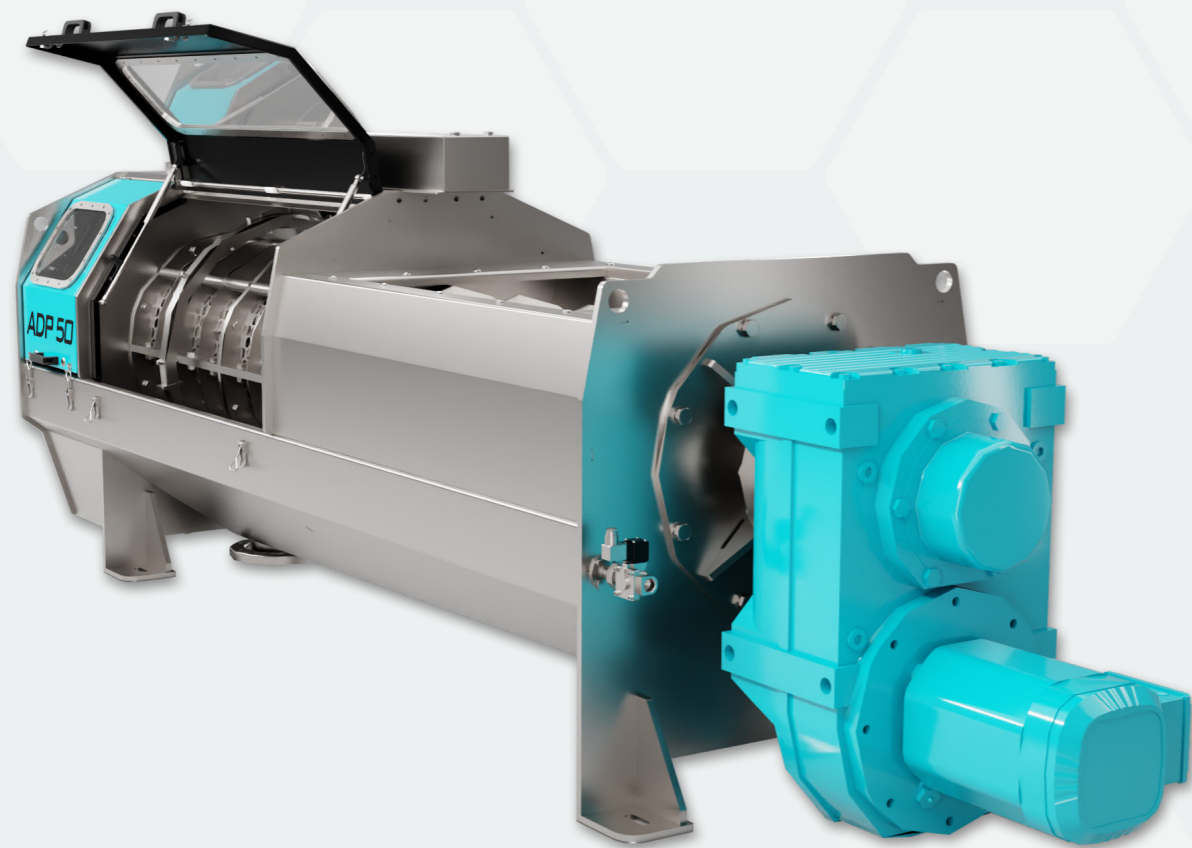

## Autofric ADP



Autofric ADP is a high-performance screw press for dewatering of industrial material but also for various sludge dewatering in, for example, municipal wastewater treatment plants with higher incoming DS content. The screw press is designed with a screw in stainless steel that rotates inside a dividible screen basket through several dewatering zones.

The screw press is fed by a screw conveyor, belt conveyor, or from a chute. Applications that have been tested include polyester fiber, food, seaweed, and sewage sludge, but there are many more potential uses where dewatering may be desirable (e.g., industrial waste or hazardous waste from slaughterhouses).



## Autofric AFP4



Autofric AFP4 is an energy-efficient screw press for dewatering of sludge. The model is specially developed to efficiently dewater smaller volumes of sludge with its simple yet effective design. AFP4 is equipped with a conical screw in stainless steel that rotates through multiple dewatering zones inside a dividible screen basket.

Like its sister model ASP, AFP4 has a fully enclosed chassis and few moving parts, making it easy to handle. The press works quietly, vibration-free, and energy-efficiently.

## SLUDGE CLEANERS

Autofric's sludge cleaners are designed to facilitate sludge handling by reducing the risk of blockages, downtime, and high maintenance costs. The solutions support more efficient and reliable processes, both in municipal facilities and across a variety of industrial environments.

### Autofric ASC

Autofric ASC is an energy-efficient in-line sludge cleaner designed to remove and dewater fibrous materials, debris, and solids from wastewater sludge, and industrial flows. Engineered for durability and minimal wear, the ASC delivers exceptional results while minimizing lifecycle costs — making it the smart choice for efficient sludge management.

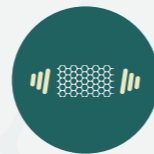
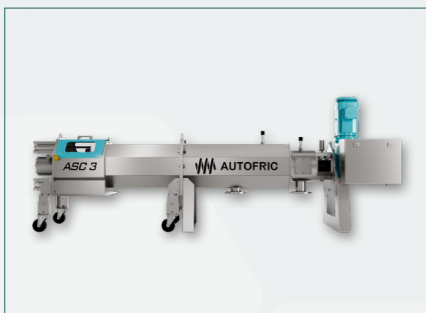

## SCREW CONVEYORS

Autofric offers customized screw conveyors for use in industry, agriculture, food manufacturing, and biofuel handling. Robust, durable, and energy-efficient conveyors with long life and minimal maintenance requirements.

### Autofric Type-E

Autofric Type-E is an innovative and effective solution for material transport in industries such as paper- and pulp mills, metal industry and waste.

Type-E, our latest model of screw conveyor, is designed to safely and reliably transport various types of bulk materials with minimal wear and maximum precision. The unique design, with troughs with curved edges enclosing the spiral, reduces material rotation and forward feed is increased. The E-model works well for both horizontal and vertical transport of goods.

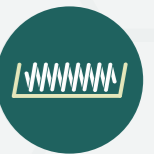
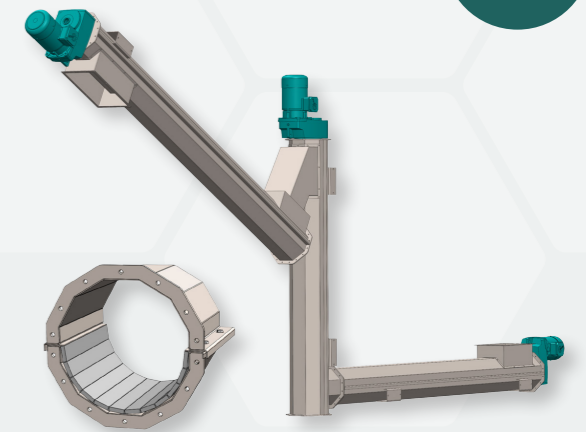

### Autofric U-screw conveyor

Autofric's U-screw conveyor is the ultimate solution for conveying bulk materials in multiple applications and installations.

The U-screw conveyor, our very first model, combines proven performance with modern innovation. The ultimate choice for horizontal transportation of materials. With its shaftless design and large buffer volume in the trough, the screw conveyor can handle large amounts of material without interruption. Furthermore, the encapsulated design allows for a dust-free environment without odors and spills.

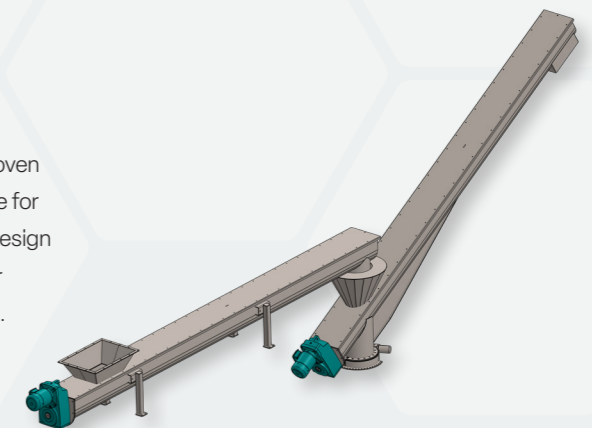

# TRANSPORT SCREWS

Customer-specific transport screws in various dimensions and materials are manufactured in our in-house developed machines. On behalf of customers, we design and produce spirals for installation in our customers' flows and machines.

## Shaftless transport screws



Shaftless transport screws provides opportunities to transport difficult materials with varying particle sizes.

Shaftless transport screws have no center tube and are particularly suitable for handling difficult materials that are sticky, wiry and irregular. The risk of material sticking or clumping is minimized, ensuring smooth and continuous transport.



## Center shaft transport screws



Transport screws with center shaft are used as a highly accurate dosing device in applications with high demands on material flow control.

With the screw welded to the center tube, the screw runs free from the trough, reducing wear and tear. Multiple entry and exit points enables efficient distribution of bulk materials.

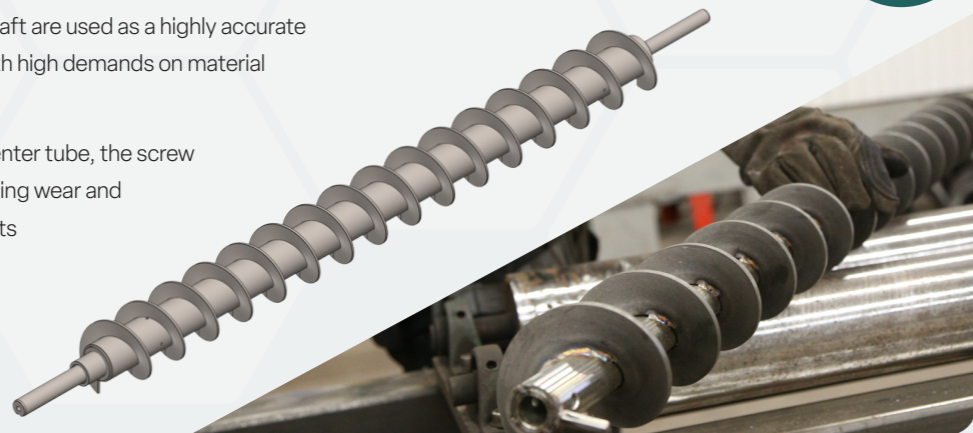

Autofric manufacture spirals for new projects or as spare parts for existing plants. The design, production technology, material properties, and thickness of the spirals contribute to extreme wear resistance and durability.

# SCREW SEGMENTS

Screw segments are used to build spirals for all kinds of transportation, pressing, dosing, etc. Segments provide many options when it comes to material, dimensions and finished design of the screw.

## Standard segments

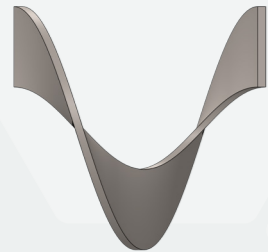

Standard segments are used for all kinds of conveying, pressing, and dosing. They can be manufactured in several different types of steel and in different dimensions.



## Figure-cut segments

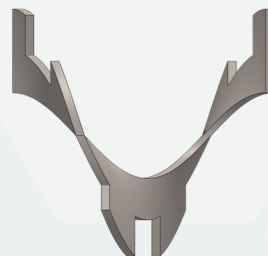

Segments are available with inner or outer notches. Inner notches are often used for conical screw conveyors and for materials that require stirring. Outer notches are used when the process requires that the material is crushed, cut, kneaded, or mixed.



## Conical segments (internal and external)

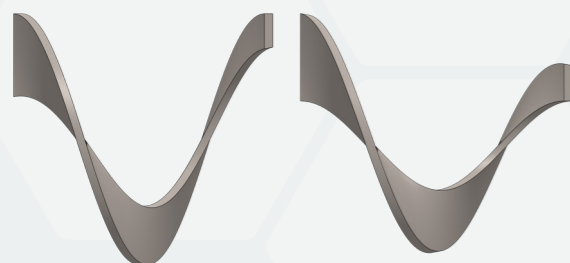

Conical segments can be used to control the filling in the segment so it doesn't pack the material.

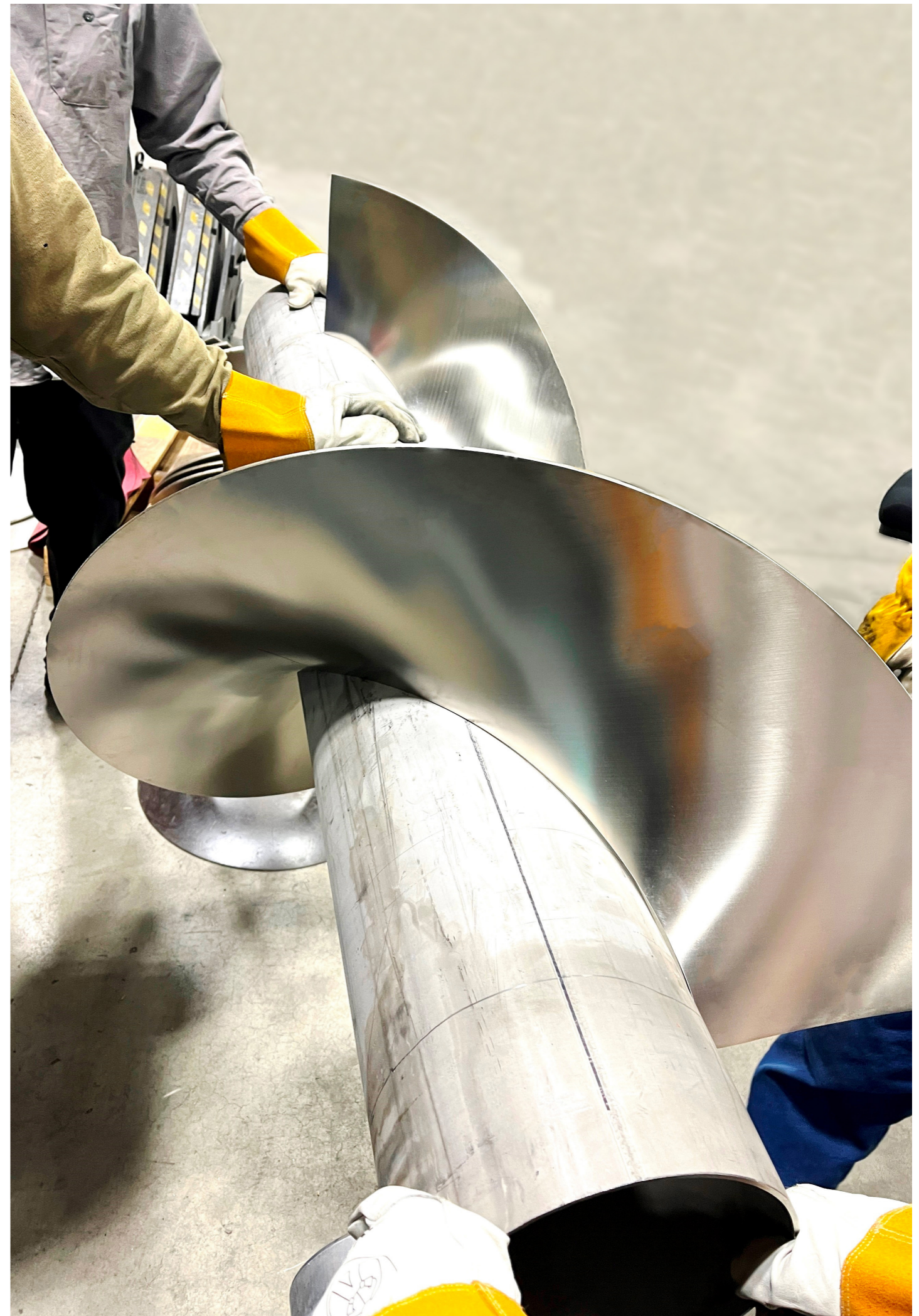



**AUTOFRIC**

**Autofric AB**

Uddeholmsvägen 59, 683 33 Hagfors, Sweden

Phone: +46 563-600 56 | E-mail: [info@autofric.se](mailto:info@autofric.se) | Web: [www.autofric.se](http://www.autofric.se)